

DTRT 400-1000

with grinder

CARATTERISTICHE COSTRUTTIVE / CONSTRUCTION FEATURES CARACTERÍSTICAS CONSTRUCTIVAS / CARACTÉRISTIQUES D'EXÉCUTION

Corpo pompa	ghisa
Pump body	cast iron
Cuerpo bomba	fundición
Corps de pompe	fonte
Girante	ghisa
Impeller	cast iron
Rodete	fundición
Turbine	fonte
Tenuta meccanica	doppia tenuta con barriera d'olio:carburo di silicio lato pompa, ceramica-grafite lato motore
Mechanical seal	double seal with oil barrier: silicon carbide on pump side, ceramic-graphite on motor side
Sello mecánico	doble sello con cámara interpuesta:carburo de silicio lado bomba, cerámica-grafito lado motor
Garniture mécanique	double garniture avec film lubrifiant:carbure de silice côté pompe, céramique-graphite côté moteur
Albero motore	acciaio AISI 304
Motor shaft	stainless steel AISI 304
Eje motor	acero AISI 304
Arbre moteur	acier AISI 304
Profondità di immersione	
Depth of immersion	max 20 m
Profundidad inmersión	
Profondeur immersion	
Temperatura del liquido	
Liquid temperature	0 - 40 °C
Temperatura del líquido	
Température du liquide	
Cavo	
Cable	H07 RNF, 10 m
Cable	
Câble	
Trituratore	acciaio inossidabile trattato
Grinder	treated stainless steel
Triturador	acero tratado
Triturateur	acier traité
Viteria	acciaio inossidabile A2
Bolts	A2 stainless steel
Tornillos	acero A2
Vis	acier A2
Base appoggio	ferro zincato
Foot support	galvanized iron
Placa base	hierro galvanizado
Plaque de base	fer galvanisé
Guarnizioni	gomma NBR
Gaskets	NBR rubber
Anilos	goma NBR
Joints	caoutchouc NBR
MOTORE / MOTOR / MOTOR / MOTEUR	
Motore 2 poli a induzione in bagno d'olio	
2 pole induction motor in oil bath	
Motor de 2 polos a inducción en baño de caeite	3~ 220/380V - 60Hz
Moteur à induction à 2 pôles en bain d'huile	
Classe di isolamento	
Insulation class	F
Clase de aislamiento	
Classe d'isolation	
Grado di protezione	
Protection degree	IP68
Grado de protección	
Protection	

DTRT 400-1000

DTRT 400-1000/P

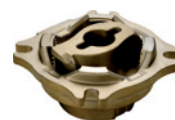

Trituratore
Grinder
Triturador
Triturateur

Pompe da drenaggio con girante centrifuga che garantisce una elevata prevalenza.

Il sistema **tritratore** permette il pompaggio di liquami con fibre tessili o filamentose liquami industriali, civili e zootecnici dove si renda necessario frantumare solidi in sospensione; disponibili sia per applicazioni mobili e fissa con piede di accoppiamento.

Centrifugal drainage pump that guarantees high head. The **grinder** allows to pumps sewage containing textile or filamentous fibres, industrial, civil and zootechnical sewage whenever suspended solids have to be crushed; available in the mobile or permanent versions with coupling feet.

Bombas de drenaje con rodete centrifugo que garantiza una elevada prevalencia.

El sistema **tritratador** permite el bombeo de aguas sucias con fibras textiles o filamentosas, líquidos industriales, civiles y zootécnicos donde se necesita triturar cuerpos, sólidos en suspensión; disponibles para aplicaciones móviles y fija con pie de acoplamiento.

Pompes de drainage avec une roue centrifuge qui garantit une hauteur manométrique élevée. Le système **tritratateur** permet le pompage de purin avec fibres textiles ou filamenteuses, purin industriel, civil et zootechnique où il est nécessaires de briser des solides en suspension; disponibles pour applications aussi bien mobiles que fixes, avec pied d'accouplement.

DTRT 400-1000 WITH GRINDER

SOMMERSIBILI / SUBMERSIBLES / SUMERGIBLES / SUBMERSIBLES / SUBMERSIBLES

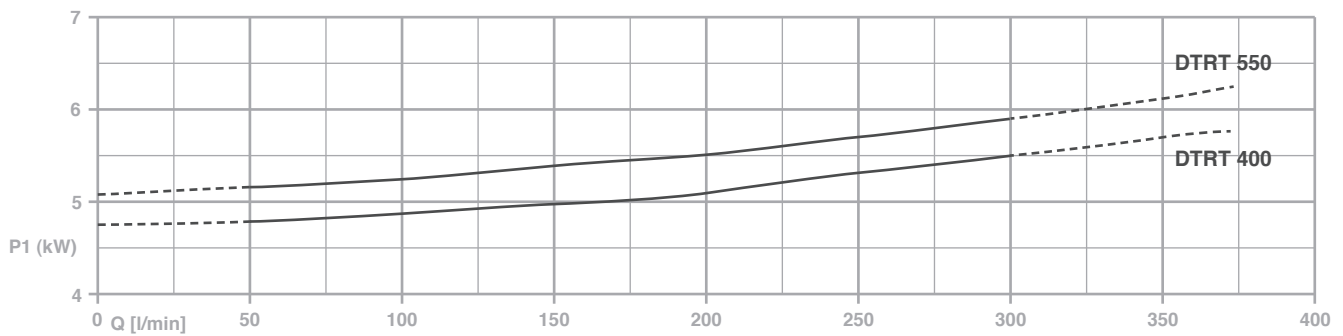
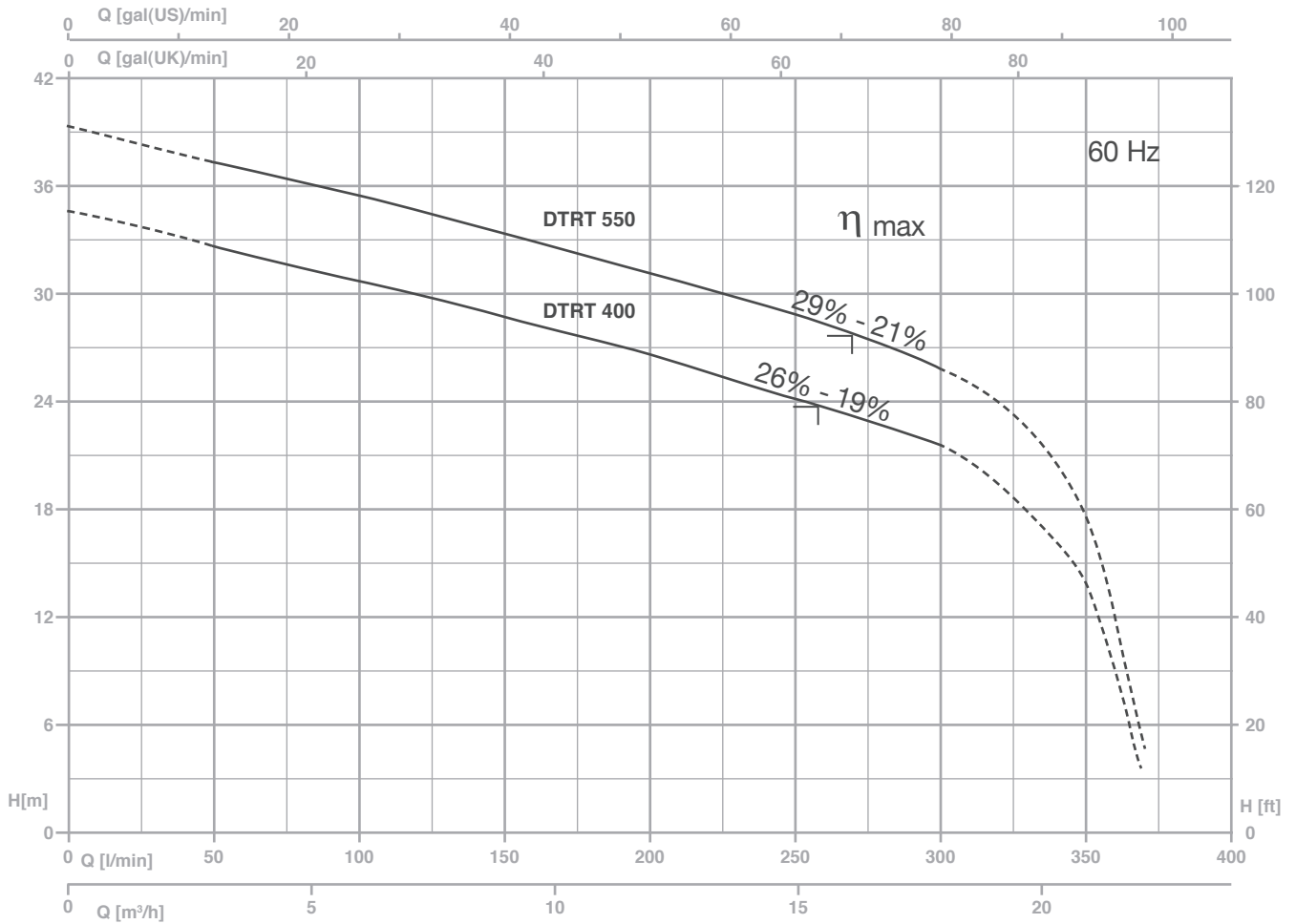

TYPE	AMPERE		
	3x220 V 60 Hz	3x380 V 60 Hz (*)	220/380 V 60 Hz λ / Δ
DTRT 400	15,9	9,2	-
DTRT 550	18,2	10,5	-

η_{max}

max rendimento idraulico e rispettivo rendimento totale
max hydraulic efficiency and respective total efficiency
máx rendimiento hidráulico y correspondiente rendimiento total
max rendement hydraulique et rendement total

(*) no standard execution

TYPE	P2		P1 (kW)	Q (m³/h - l/min)							
				0	3	6	9	12	15	18	
				0	50	100	150	200	250	300	
3~	(HP)	(kW)	3~	H (m)							
DTRT 400	4	3	5,1	34,8	32,7	30,8	28,8	26,8	24,4	21,8	
DTRT 550	5,5	4	5,9	39,5	37,4	35,5	33,5	31,3	29,0	26,0	

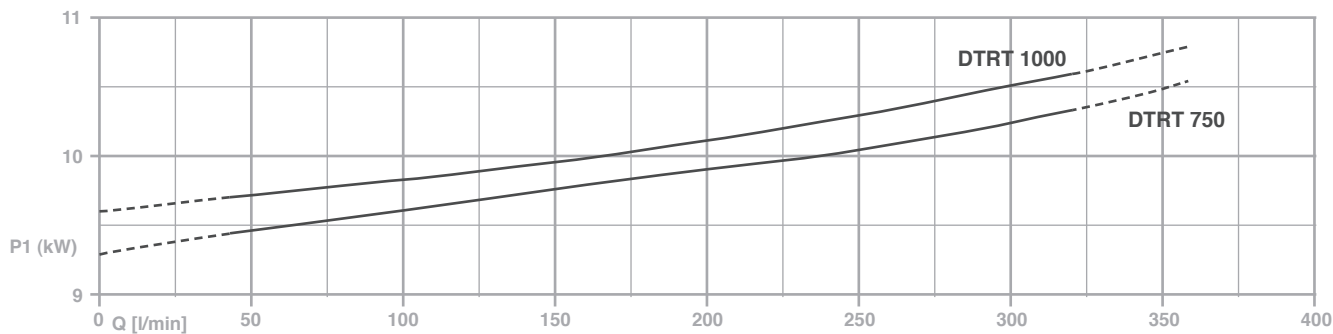
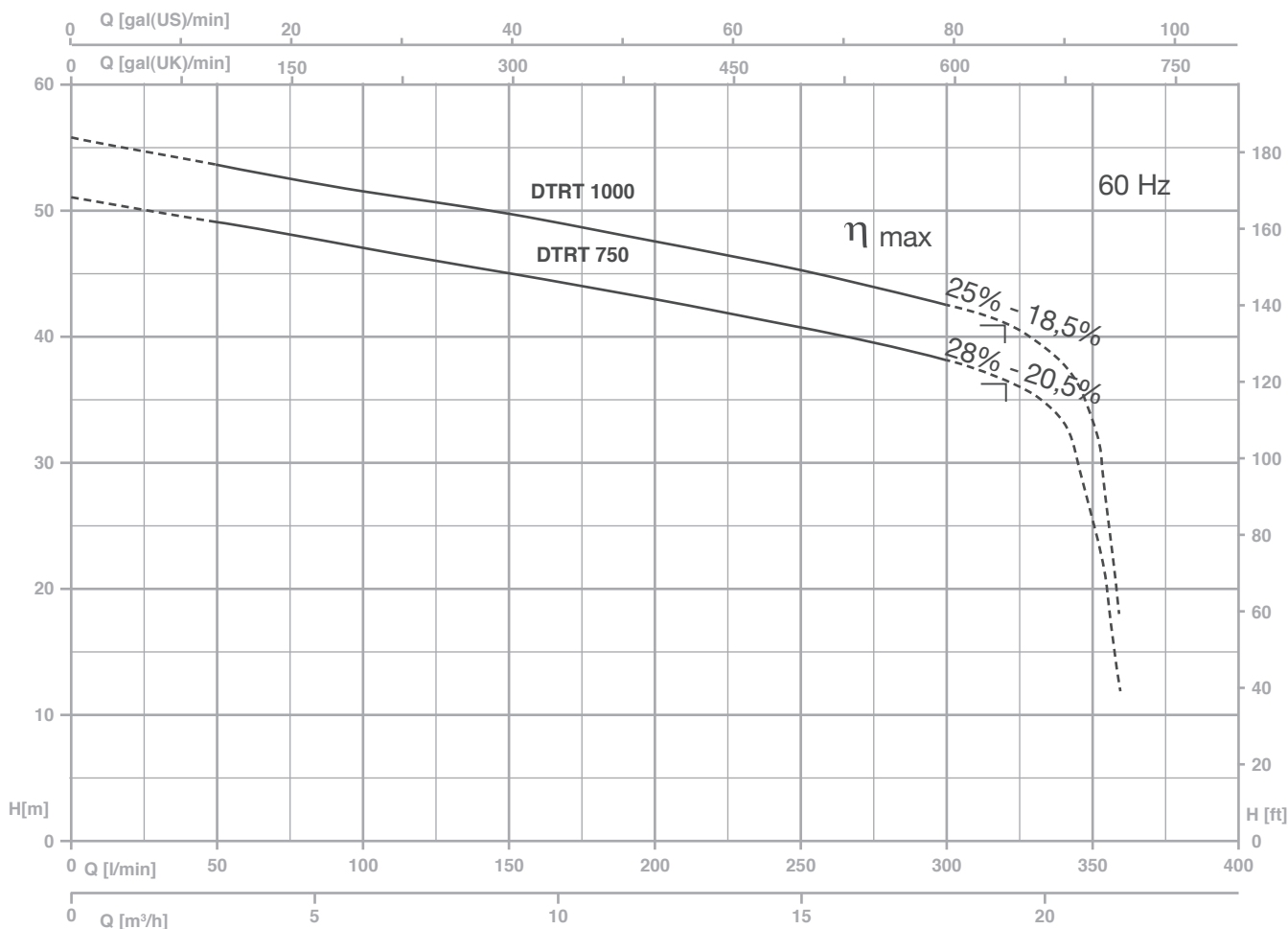

TYPE	AMPERE		
	3x220 V 60 Hz	3x380 V 60 Hz (*)	220/380 V 60 Hz λ / Δ
DTRT 750	-	18,8	32,5
DTRT 1000	-	19,0	32,9

η_{max}

max rendimento idraulico e rispettivo rendimento totale
 max hydraulic efficiency and respective total efficiency
 máx rendimiento hidráulico y correspondiente rendimiento total
 max rendement hydraulique et rendement total

(*) no standard execution

TYPE	P2		P1 (kW)	Q (m³/h - l/min)								
				0	3	6	9	12	15	18	19,2	
	(HP)	(kW)	3~	0	50	100	150	200	250	300	320	
	H (m)											
DTRT 750	7,5	5,5	10,3	50,8	48,9	46,9	45,0	43,0	40,9	38,4	36,8	
DTRT 1000	10	7,5	10,6	55,7	53,5	51,5	49,6	47,6	45,4	42,7	41,2	

DTRT 400-1000 WITH GRINDER

ACCESSORIES

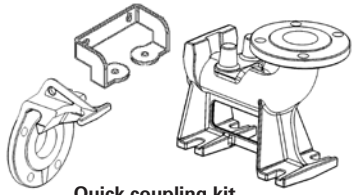

Quick coupling kit



Counterflange

Mt/Mf: livello minimo di funzionamento continuo
 Mt/Mf: lowest level for continuous duty
 Mt/Mf: nivel minimo de funcionamiento continuo
 Mt/Mf: niveau minimum de fonctionnement continu

mt/mf: livello minimo di funzionamento
 mt/mf: lowest working level
 mt/mf: nivel minimo de funcionamiento
 mt/mf: niveau minimum de fonctionnement

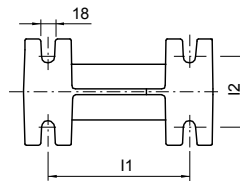
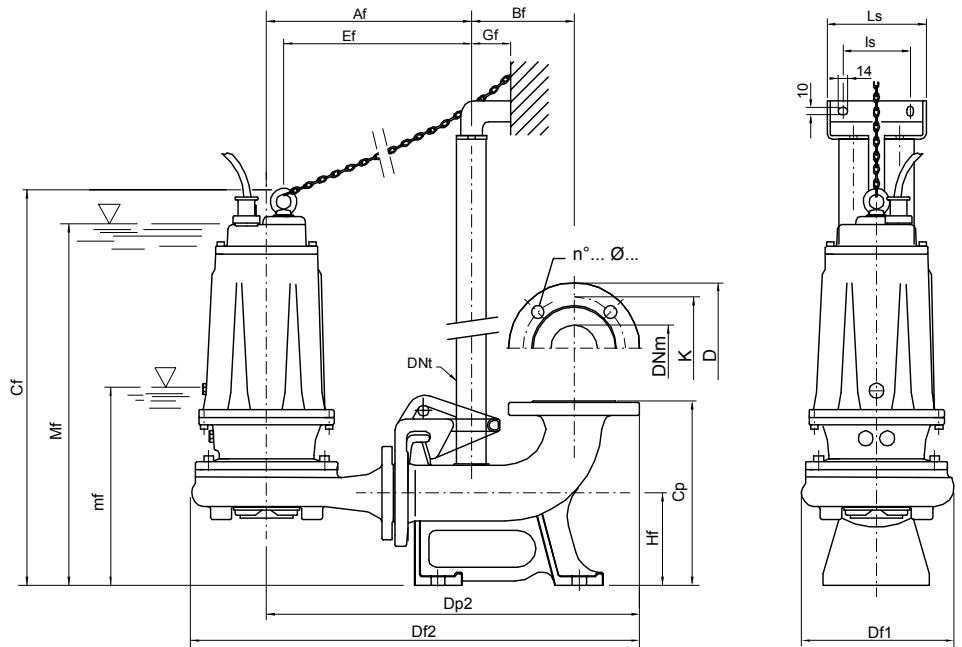
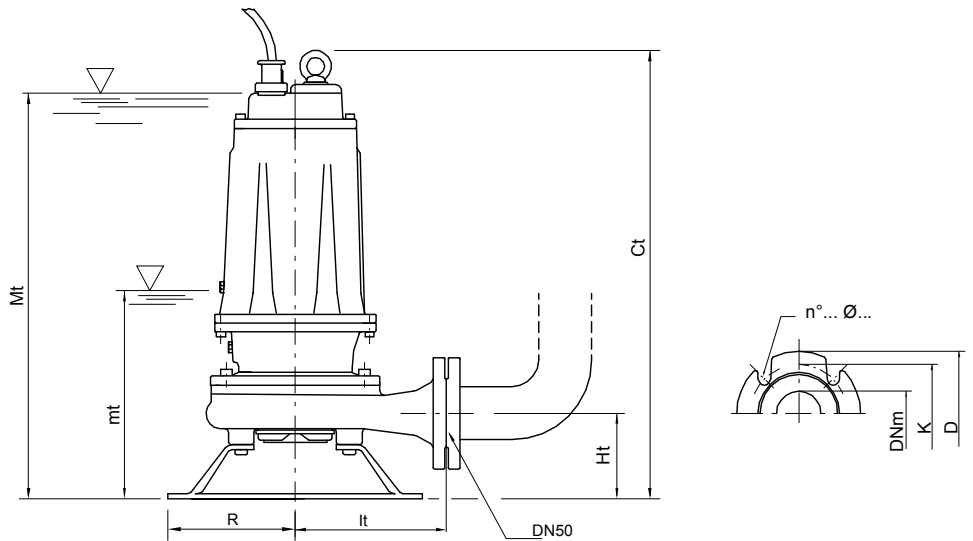

Flange UNI PN 10 (mm)

DNm	K	D	n°... Ø...
50	125	165	4... 18...
65	145	185	4... 18...

TYPE	DIMENSIONS (mm)								Kg
	Ct	Ht	R	lt	mt	Mt	DNm		
DTRT 400	595	112	160	190	265	550	50	58	
DTRT 550	595	112	160	190	265	550	50	66	
DTRT 750	680	160	180	250	280	630	65	94	
DTRT 1000	680	160	180	250	280	630	65	97	

TYPE	DIMENSIONS (mm)																	
	Af	Bf	Cf	Cp	Df1	Df2	Dp2	DNt	Ef	Gf	Hf	I1	I2	Is	Ls	mf	Mf	DNm
DTRT 400/P	300	145	614	260	237	654	538	1" 1/4	269	55	130	200	100	95	140	290	566	50
DTRT 550/P	300	145	614	260	237	654	538	1" 1/4	269	55	130	200	100	95	140	290	566	50
DTRT 750/P	331	145	656	260	279	710	569	1" 1/4	297	55	130	200	100	95	140	290	600	65
DTRT 1000/P	331	145	656	260	279	710	569	1" 1/4	297	55	130	250	100	95	140	290	600	65